

200 x 90 x 30 cm*

78.7" x 35.4" x 11.8"

ADVANTAGE 6/300

5 Años Garantía
Years Guarantee
Jahre Garantie
Ans Garantie
Anos de Garantia
SIMONRACK



**450 kg
(1000 lb)
Total**

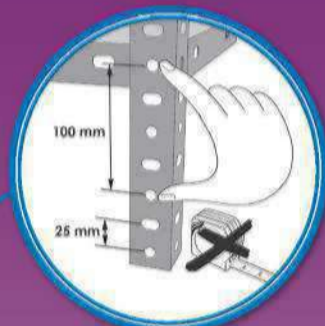

**Simon
Rack**
SINCE 1964 - MANUFACTURER

*MEDIDAS EN USO: 2003 x 914 x 314 mm
USED MEASUREMENTS: 78.88" x 35.98" x 12.36"



ESTANTERIAS SIMON S.L. B.50.556.463
PG. ALFAMEN C/ POLIGONO C, Nº3
ALFAMEN (ZARAGOZA)



www.simonrack.com



INSTRUCTIONS

